



EUROPEAN ANTENNAS

Excellence through design
Creative in concept

FPA17-16RL TRIPOD MOUNT

MODEL: 066A

Ground Mounting Kit for 1096B antenna, to be used in conjunction with Mounting Kit 056A

MATERIAL: Mild Steel Tubing

FINISH: Matt Black

Supplied with 3 ground pegs

TOP VIEW

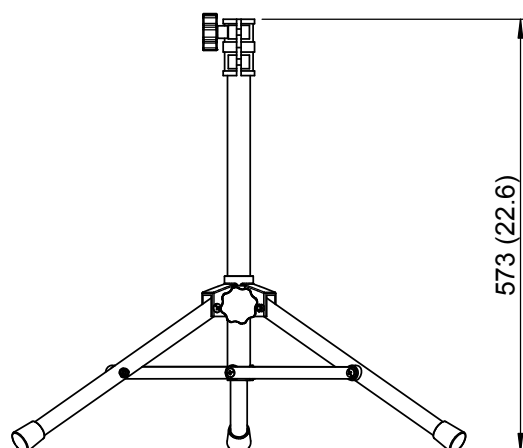
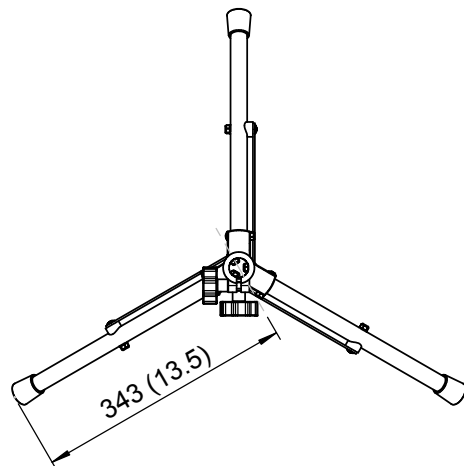

SIDE VIEW

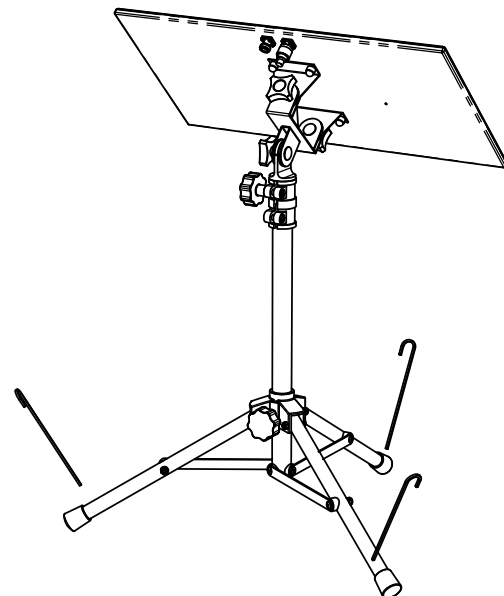

PICTORIAL VIEW
(SHOWN MOUNTED TO
056A BRACKET ASSEMBLY &
1096B ANTENNA)

DIMENSIONS: mm (inches)	H
GA: 066A - 1	Issued: 071204

EUROPEAN ANTENNAS LTD.

Tel: +44 (0)1638 731888
Fax: +44 (0)1638 731999

LAMBDA HOUSE, CHEVELEY
NEWMARKET, SUFFOLK, CB8 9RG,
UNITED KINGDOM

E-Mail: sales@european-antennas.co.uk
Website: www.european-antennas.co.uk